

PERMANENT INSTRUMENT

ACTEON 2054-SB3-T and ACTEON 2055-SB50-T

New field transmitters for sludge blanket and temperature detection

- Sturdy, watertight, easy to install
- Widescreen graphic display: instant measurements, trend line, calibration state
- Quick and simple intuitive programming
- 4-20 mA outputs, programmable relays



Simple, sturdy and reliable like its legendary predecessor, the APF series, with additional digital intelligence and leading-edge technology.

Technical specifications	
Ranges	0.0 to 100.0% (VB20 0-3 g/L and VB5 0-50 g/L sensors)
Measurement accuracy	±2%
Temperature measurement range	-10.00 to +50.00°C
Temperature measurement accuracy (°C)	±0.1°C
Casing	ABS
Protection	IP 65
Operating temperature	-25°C to +55°C
Dimensions (L x W x D) /Weight	173 x 195 x 103mm / 1.5kg
Display	Widescreen back-lit graphic display: 240 x 128 pixels (108 x 58mm)
Power supply	230/115 Vac 60Hz, Optional: 24Vdc
Max power consumption	10VA
4-20mA outputs	2 galvanic isolation outputs (max load 700ohms): - Adjustable from 0.00 to 20.00g/L or from 0.00 to 50.00g/L - Adjustable from -10.00°C to +50.00°C
Relay outputs	2 relays that can be configured in 2 different modes: - Adjustment in alarm mode (1 sludge blanket and 1 temperature (°C) threshold) - Adjustment in adjustment mode (2 sludge blanket thresholds with 2 relays)

The standard ACTEON 2054 and 2055 units come with a VB5 or VB20 sensor connected to 10 metres of cable.

Fields of application:

- A reading of 100% indicates ultra-clear water while water with large amounts of suspended matter (concentrated sludge) will display 0% (any light is entirely absorbed).
- Using the new ACTEON 2054 and 2055 as fixed units will optimise sludge level detection in settling tanks: Wastewater treatment (primary and secondary settling tanks)

Applications in oil separators

Sludge blanket and temperature sensor:

PONCIR-VB5-10 and PONCIR-VB20-10

- **Measurement principle:** Optical absorption of infrared light, regulated and pulsed emission (10Hz frequency)
- **Dimensions:** Length: 210mm
- **Weight:** 1.2kg
- **Materials:** PVC and special glass, IP68
- **Temperature compensation (°C) :** automatic per CTN of +5 to +30°C
- **Emission wavelength:** 950nm (infrared)
- **Cable:** Multiple coated wires, polyurethane sheath. 10m standard length (up to 100m on request)

Installation options: *Fixed sensor-holder perch, accessories for in-pipe installation*



The SB5 and SB20 optical sensors consist of three parts

The head of the sensor

The sensor is cylindrical and has a diametral cavity with parallel walls (optical length 5mm [VB5] or 20mm [SB20]). Two quartz disks mounted on ring-type joints let through the radiation and protect the different diodes. This assembly absorbs thermal shocks and allows the sensor to operate up to 100°C.

The body of the sensor

Equipped with a set of electronic boards, diode feeds and signal and amplification processors, the body of the sensor can be positioned up to 100m from the transmitter sensor.

The sleeve

This is where the electronic boards are connected to the coated cable. A cable gland is used to keep it watertight.

Temperature Sensor:

Delrin, Stainless steel, Silicone - IP68
 Dimensions: Diameter 3mm (sensor), Length 115mm
 Weight: 40g
 Cable: 10m standard length

Accessories for electronic unit installation:

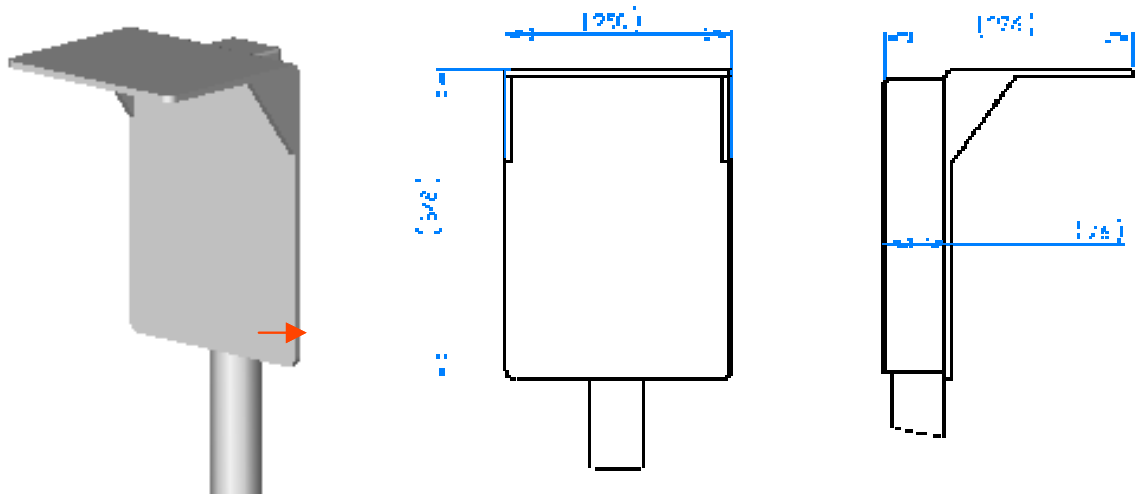

Hood mount for the ACTEON 2054 and 2055 transmitter (**PON-PDPCV-1** for 1 transmitter and **PON-PDPCV-2** for 2 transmitters).

Accessories for sensor installation in tanks and open canals:

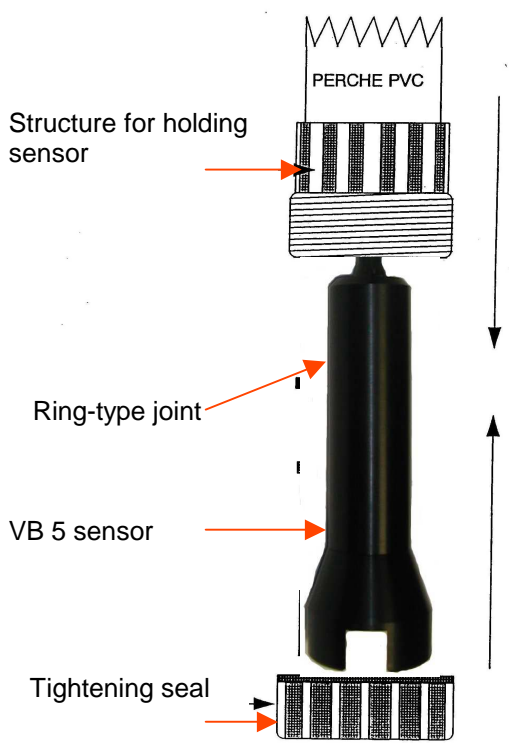

Stainless steel mount (**PONSPFR-1C** for 1 perch and **PONSPFR-2C** for 2 perches)

Elbowed Sensor-Holder Perch (**PONPPCC-CIR**)

30cm minimum

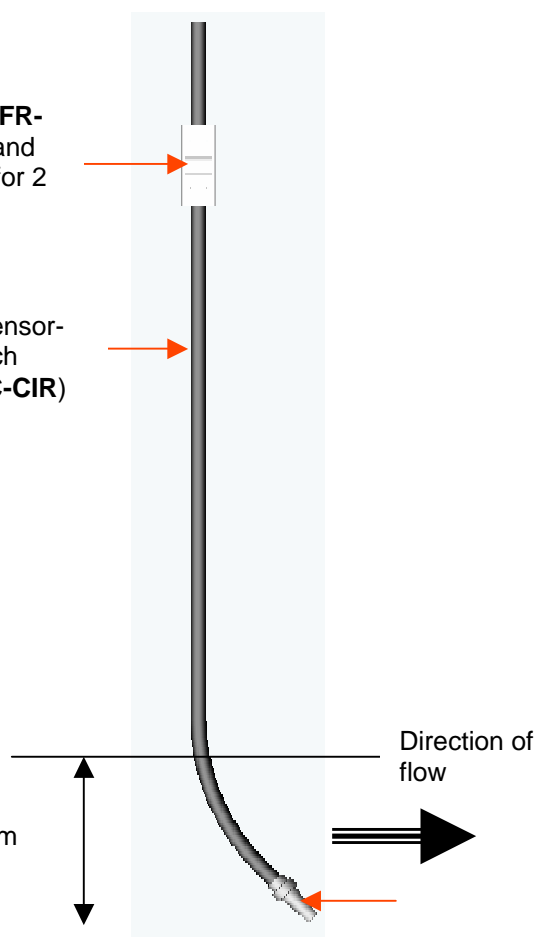

Accessories for sensor installation in pipes:

View from above

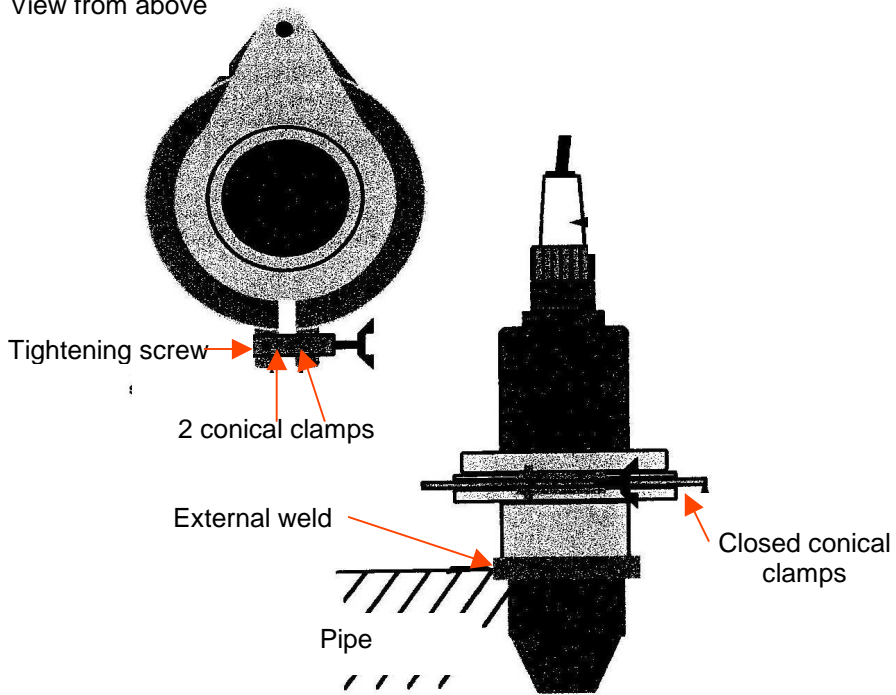

VB5 sensor for in-pipe installation with a quick mounting/dismounting system using conical coupling clamps